

# SIEMENS

*Ingenuity for life*

Industrial machinery

## TATXA

Labeling machine manufacturer retools product development process

### Products

Solid Edge, Simcenter

### Business challenges

Reduce materials weight

Decrease costs

Increase machinery yield

Improve customer's operating environment – plant ergonomics and work quality

Increase innovation

### Keys to success

Use 3D visualization for design, plant layout and sales

Utilize simulation to automate structural analysis, reduce errors and accurately project stresses

### Results

Optimized materials use

Implemented virtually error-free design process

Reduced costs across operations

Increased machine availability and opportunity

Improved product performance as well as product aesthetics

"Using Solid Edge to design

**TATXA engages Solid Edge and Simcenter Femap to significantly improve start-to-finish operations, reducing costs while improving product form and function**

### Specializing in the design and production of labeling machines

Sistemas de Etiquetas y Embalaje is widely known to its customers under the trade name TATXA. The company specializes in designing and manufacturing different

types of labeling machines, including linear and self-adhesive units as well as rotating units that produce cold or hot glue. TATXA has been developing labeling machines for 40 years and has demonstrated its experience by working with more than 3,000 customers. As a result, the company understands the importance of providing products that deliver added customer value through a personalized and attractive appearance that distinguishes its labeling products from mass-produced packages.



and develop our machines has resulted in numerous concrete advantages across all levels of the company.”

Simone Casadio  
Technical Department  
Engineer  
Sistemas de Etiquetaje y  
Embalaje S.L

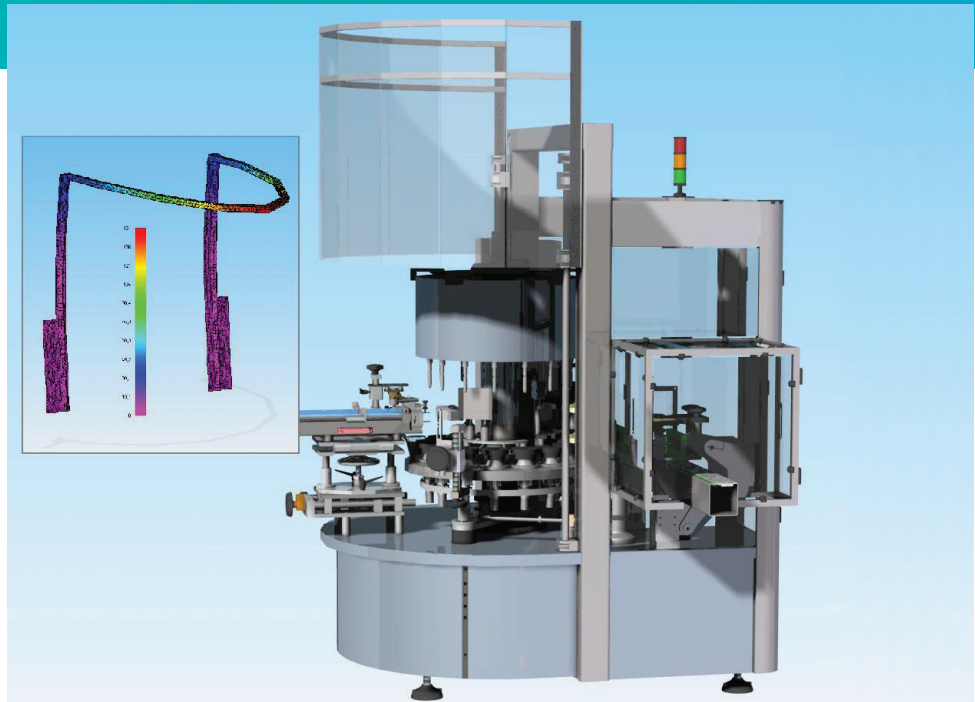

TATXA's R&D labeling techniques enable the company to propose individualized solutions for its customers' product and production-specific requirements, as evidenced through its ability to deliver and install more than 4,300 labeling machines with unique characteristics to its customers' industrial plants. TATXA prides itself on the precision of its machines – precision that ensures the perfect finish of a labeled product, including the adjustment and application of labels in any format or material without incurring unnecessary waste.

From initial design to technical solutions applied during manufacture, TATXA labeling machines are designed as production units capable of delivering maximum yield and industrial reliability. The company's machines are capable of labeling up to 700 packages per minute, depending on the type of machine and packaging. They are able to affix labels and full/partial wrap-around labels on cylindrical containers, as well as apply packaging on various shapes.

The need for versatility was a key element in the company's decision to use Solid Edge® software. Simone Casadio, an engineer in TATXA's Technical Department,

notes, “Using Solid Edge to design and develop our machines has resulted in numerous concrete advantages across all levels of the company. For example, our Sales division can present details of the machines to current or prospective customers, integrating rendered images of the machines in photographs of the packaging lines. This type of 3D layout helps the customer optimize its plant's space, improving the location of the machine and other external elements, such as electrical cabinets and emergency buttons. Moreover, this creates crucial advantages in terms of ergonomics and work quality.”

#### **Saving weight, hours of machining and a great deal of money**

“It's in our day-to-day design activities that Solid Edge proves itself,” says Casadio. “In industrial machinery where containers or any other type of packaging is involved, the weight of the static components was never going to be a problem. But the cost of materials is an issue. For example, the plates of a base, the tie rods of a cab, the supports of a brush or of a photocell, in 90 percent of the cases, all these components used to be over-sized to ensure their rigidity. But today raw materials are very

## Solutions/Services

Solid Edge

siemens.com/solidedge

Simcenter Femap

siemens.com/simcenter-femap

## Customer's primary business

TATXA S.L specializes in the production of labeling machines for the food, cosmetic and pharmaceutical industries, as well as for cleaning products and other special applications.

www.tatxa.com

## Customer location

Polinyá, Barcelona  
Spain

**"Thanks to Solid Edge, we are able to clearly visualize and check our machines before we make them, and implement the necessary changes that enable the optimal coexistence of form and function."**

Simone Casadio  
Technical Department  
Engineer  
Sistemas de Etiquetaje y  
Embalaje S.L.

expensive, and the use of structural analysis tools like Simcenter™ Femap™ software makes it possible to optimize material use for the design, saving weight, hours of machining and a great deal of money."

Casadio elaborates: "Besides optimizing the design, the integration of Simcenter Femap analysis tools with Solid Edge helps us solve the opposite problem. We can now size parts more accurately, reduce the margin of error and ensure that they will not fail or wear excessively for the calculated stress levels."

Designing with Solid Edge provides TATXA with a single digital model. As a result, if a change is made, the company's design process is no longer at risk since views and cutting plans are always updated. The integration of Solid Edge across assemblies, parts and drawings resolves the traditional change-related dilemma; now, each component is updated after any modification, which ensures that changes are constantly implemented across disciplines. Casadio notes, "Automatic updating of changes by Solid Edge, for example, enables our Purchasing Department to update costs or warn our suppliers about part-related changes that they have to take into account."

## Automating processes

Rotating machines typically include a series of standard tools and parts that change according to the dimensions of the containers, which move along the packaging-labeling line. These parts (also known as the "package format") present a number of parameters that define the

diameter of the containers, their height, shape (whether cylindrical or conical), the distance between the containers (the machine pitch), the number of divisions in the input and exit conveyors to the central carousel of the machine as well as various other attributes.

TATXA's Technical Department creates a spreadsheet that includes all of these parameters. Then, using Solid Edge, department engineers draw a prototype of the package format and link the assembly variables with those of the spreadsheet. This process transforms a cumbersome and error-prone 2D task into an automated and sound 3D process.

## Optimizing form and function

Solid Edge also plays a significant role in improving the aesthetics of TATXA's designs by enabling the company to use rounded edges and elegant styling in the right proportions. Casadio explains, "Thanks to Solid Edge, we are able to clearly visualize and check our machines before we make them, and implement the necessary changes that enable the optimal coexistence of form and function."

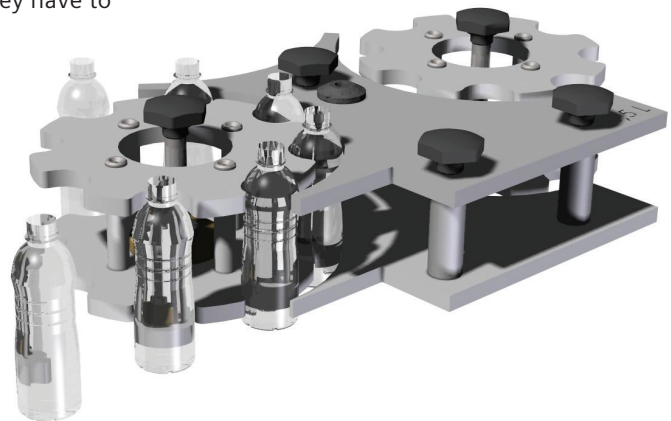

## Siemens Digital Industries Software

Americas +1 314 264 8287  
Europe +44 (0) 1276 413200  
Asia-Pacific +852 2230 3333

© 2020 Siemens. A list of relevant Siemens trademarks can be found [here](#). Other trademarks belong to their respective owners.  
33484-C7 12/20 KN

siemens.com/software